

# **FORBIX SEMICON®**

## **A Design & Manufacturing Company**

### **FORBIX SEMICON® Factory Manufacturers**

Wireless Nurse Call System  
Wireless Panic Alarm System  
Wireless Attendant Calling Systems  
Queue Management Solutions and Token Displays  
Long Range Radio RF Transmitter Receiver  
Wireless RF Industrial Transmitter and Receivers  
Wireless Traffic Light Controllers  
Air Quality Monitors  
Automatic Water Level and Pump Controllers  
Customized Automation Solutions

## FORBIX SEMICON® Products at a glance



### Wireless Nurse Call System

Advanced wireless nurse call solutions for hospitals and senior care facilities. Reliable, scalable, and easy to install.



### Wireless Panic Alarm Solutions

Instant alert systems for offices, factories, oil fields, and residential communities. Secure and robust wireless technology.



### Wireless Attendant Calling Systems

Efficient calling solutions for guest houses, elderly care, and hospitality. Enhance service and response times.

## FORBIX SEMICON® Products at a glance (contd...)



### Queue Management Solutions

Digital token display and dispensers for banks, hospitals, and service centers. Streamline customer flow.

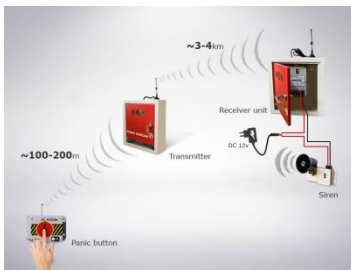

### Wireless Long Range Transmitter Receiver (3-4 Kms)

Industrial automation, motor and conveyor control, and alerting over 2-3Kms range.

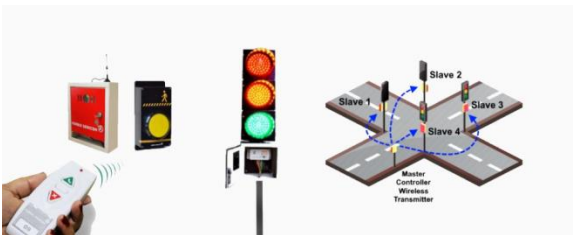

### Automatic Traffic Light Controllers

Smart intersections, pedestrian crossings, parking lots, and emergency vehicle priority.

# Products and Applications

## FORBIX SEMICON® products applications – a brief overview

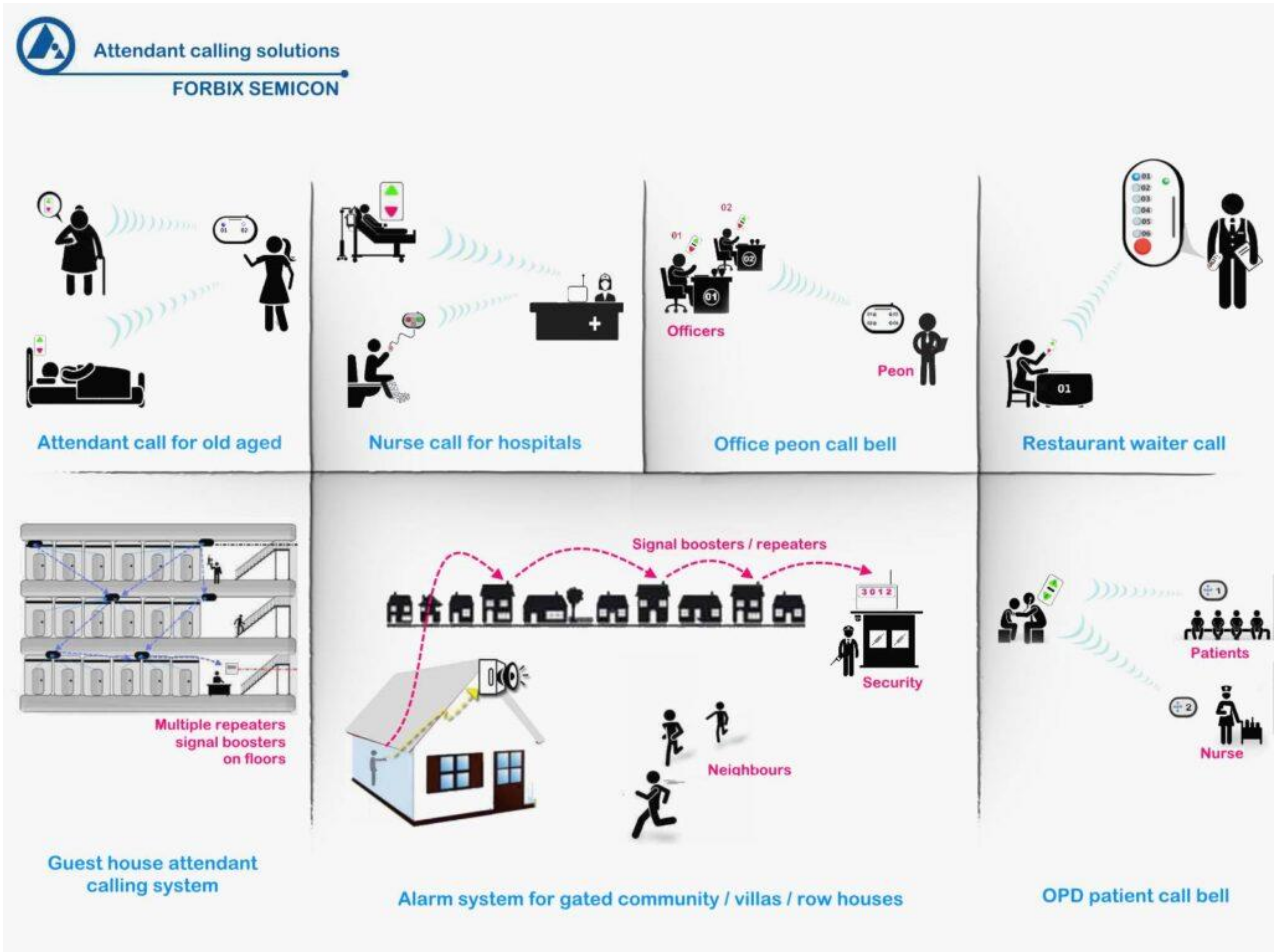

# Products and Applications

## FORBIX SEMICON® products applications – a brief overview (contd...)

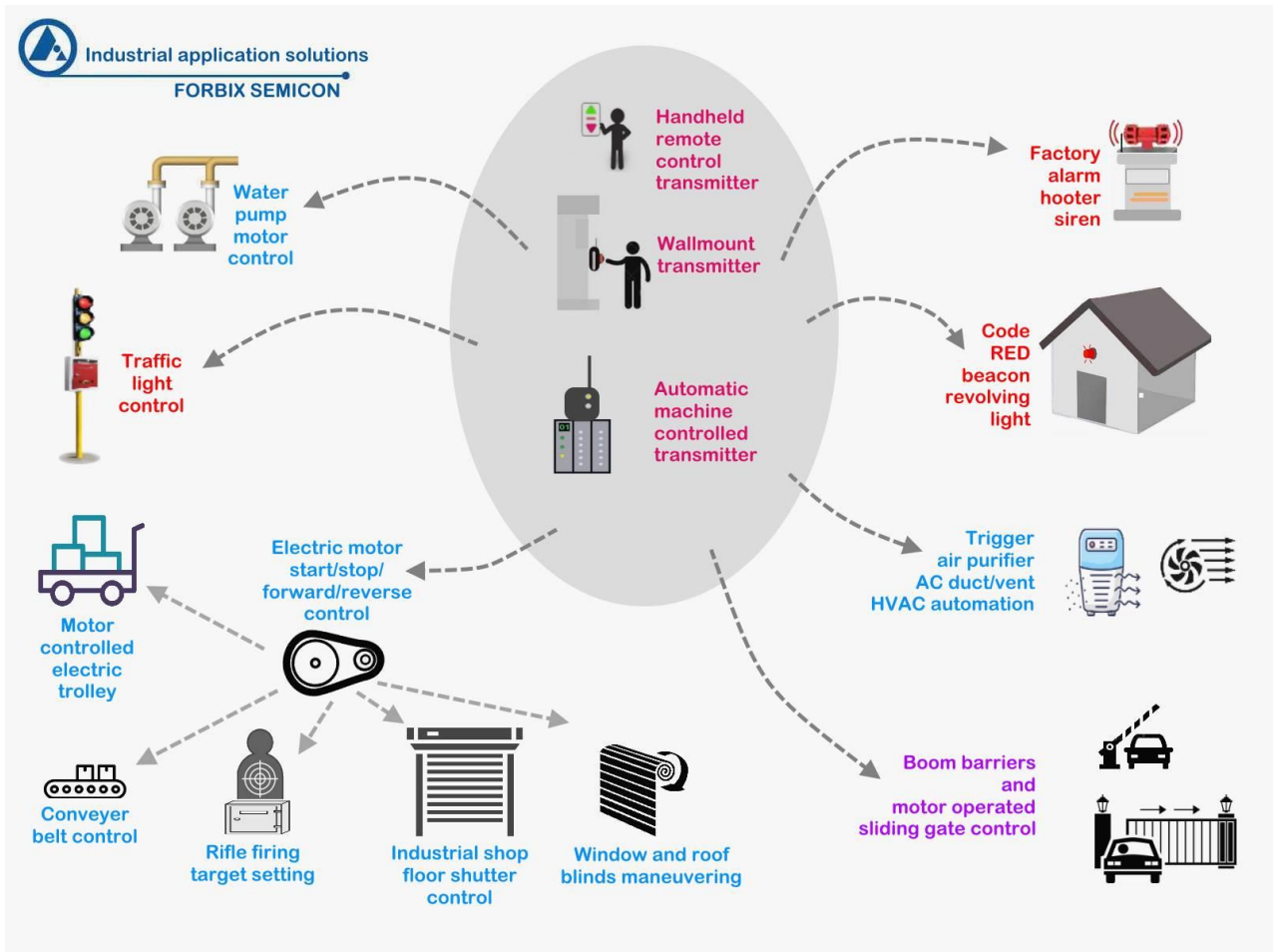

# Wireless Nurse Call System

## Components of Wireless Nurse Call System

### Wireless Patient Remote Control

Signal range: 30-40m (indoors), 100-120m (outdoors)  
Battery operated (3-4yrs battery life)  
Elegant, ergonomic, light weight, reliable, durable



### Wireless Pull Chord Button

Signal range: 30-40m (indoors)  
Battery operated (3-4yrs battery life)  
0.8-1.5m pull string



### Receiver Console Nurse Station

VGA monitor connection  
No need of external computer  
Can accommodate over 200+ beds  
Multiple display themes  
Alpha-numeric bed/room numbers  
On the fly user configurable settings  
WiFi connection to parallel monitors  
Works on 12VDC (adapter)



### Signal Repeater Booster

Leaves no corner of the building out of range  
Improves poor signal to noise ration (SNR)  
Works on 12VDC (adapter)



# Wireless Nurse Call System

## Components of Wireless Nurse Call System (contd...)

### Corridor Module Indicators

- Quick indication in the corridors
- Alerting blue color lights
- Displays room/bed numbers
- Beeping sound alert
- Works on 12VDC (adapter)



### Door Module Indicators

- Quick indication outside the rooms
- Alerting blue color lights
- Displays room/bed numbers
- Beeping sound alert
- Works on 12VDC (adapter)



### Wired Nurse Call Bell Solutions

- Simple cost effective wired call bell with receiver
- Supports 10 call bells
- Can Expand to 40..100 beds as well
- Beeping alert sound
- Works on 12VDC (adapter)



# Wireless Nurse Call System

## Nurse Call System – Advanced Architecture

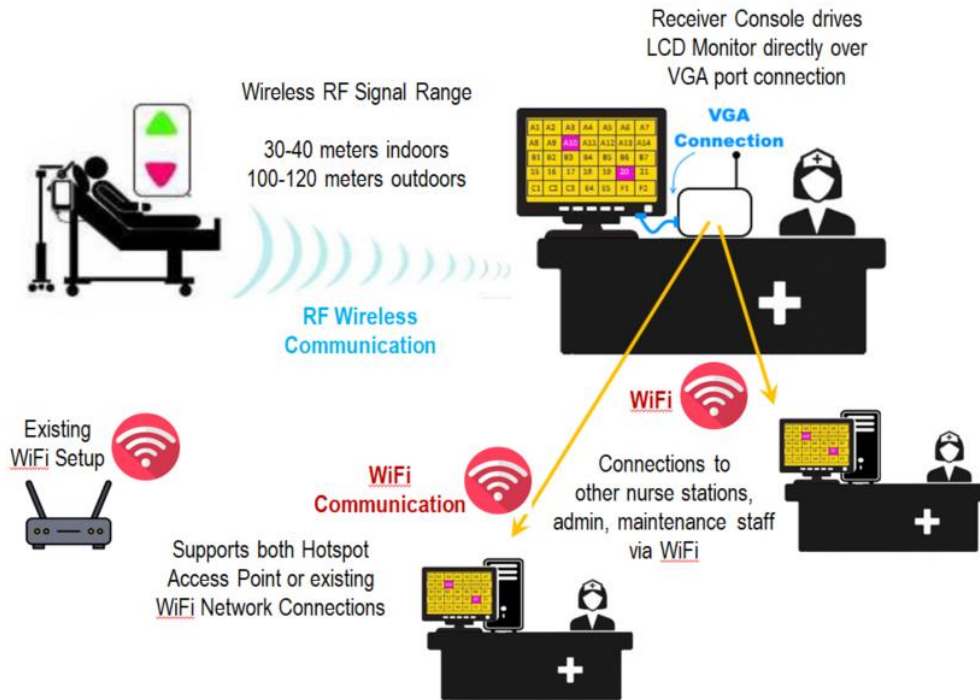

**FORBIX SEMICON** 

No wiring  
Quick installation  
Zero maintenance  
Plug-n-play  
Expandable  
Modular  
Cost effective

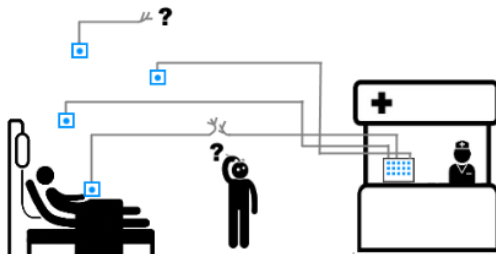

**Wired Solution**



**Wireless Nurse Call System**

# Wireless Nurse Call System

## Wireless Nurse Call System – application

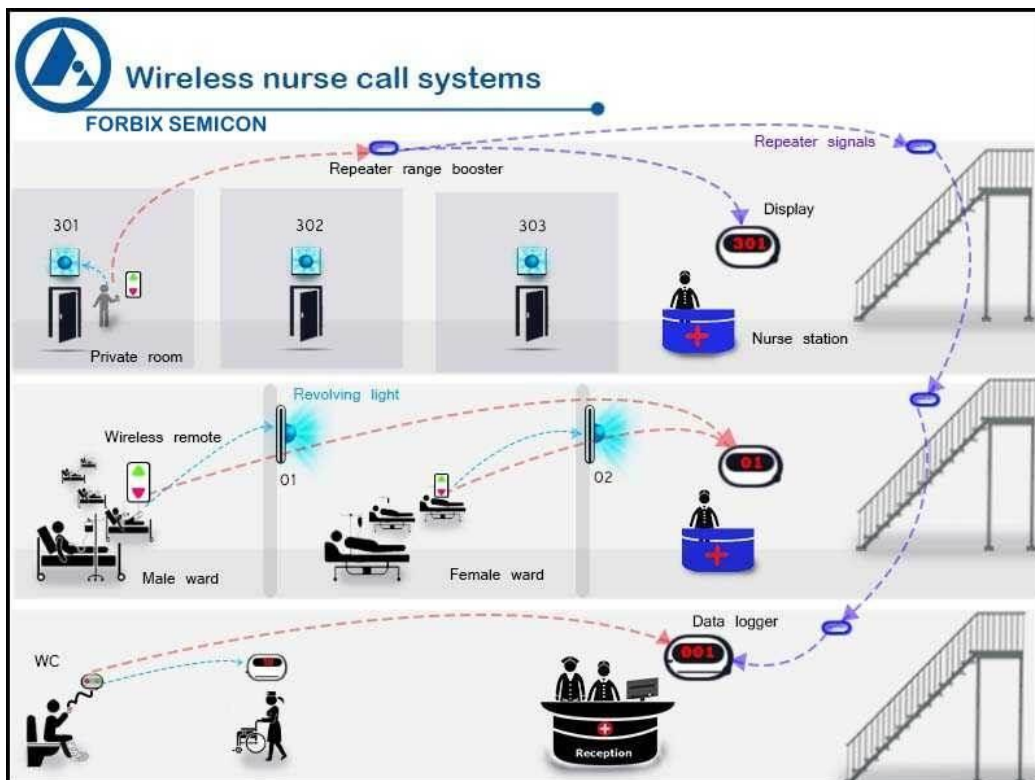
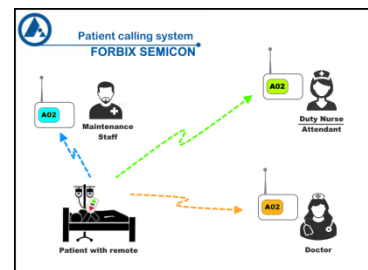
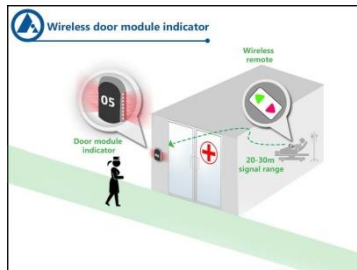
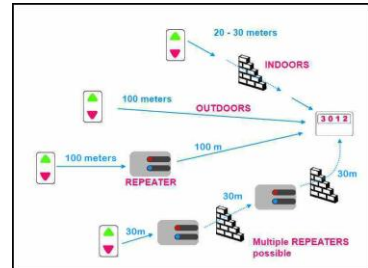
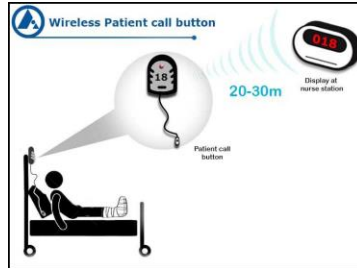
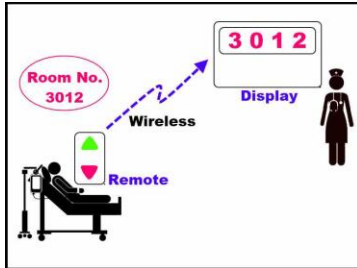

# Wireless Panic Alarm System

## Components of Wireless Panic Alarm System

### Wireless Panic Button

Signal range: 30-40m (indoors), 120-150m (outdoors)  
Battery operated (3-4yrs battery life)  
IP65 weather proof enclosure  
Flanges to secure on the wall with screws  
Panic alert button / cancel button  
Customized buzzing sound on button press



### Siren with Indicator

Loud 108 decibel siren alarm sound  
6 to 15 LED indicators to show panic button numbers  
Works on 12VDC (adapter)



### Code Red Beacon Light with 2-Digit Display

Beacon red light  
85 decibel siren sound  
00-99 numbers on 2-digit display  
Works on 12VDC (adapter)

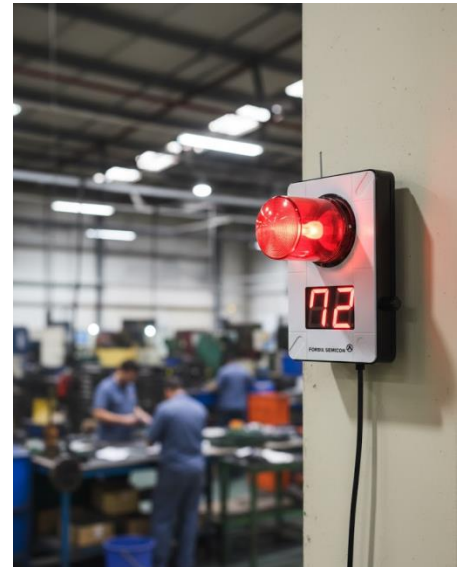

# Wireless Panic Alarm System

## Components of Wireless Panic Alarm System (contd...)

### Panic Alarm Siren

Signal range: 30-40m (indoors), 120-150m (outdoors)  
Battery operated (3-4yrs battery life)  
IP65 weather proof enclosure  
Flanges to secure on the wall with screws  
Panic alert button / cancel button  
Customized buzzing sound on button press



### Siren with Indicator

Loud 108 decibel siren alarm sound  
6 to 15 LED indicators to show panic button numbers  
Works on 12VDC (adapter)

### Code Blue Beacon Light with 2-Digit Display

Beacon blue light  
85 decibel siren sound  
6-20 indicators for each calling button  
Works on 12VDC (adapter)



# Wireless Panic Alarm System

## Wireless Panic Alarm System – application

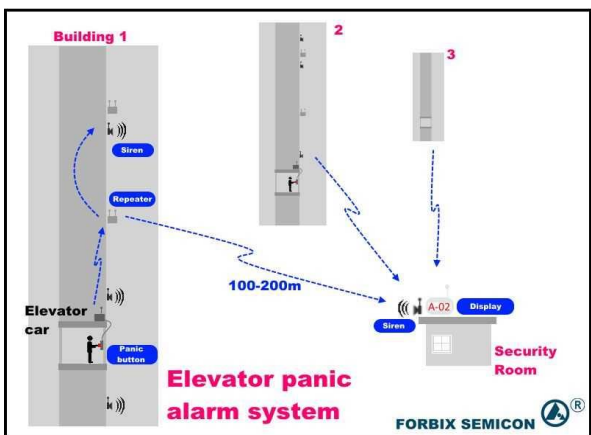
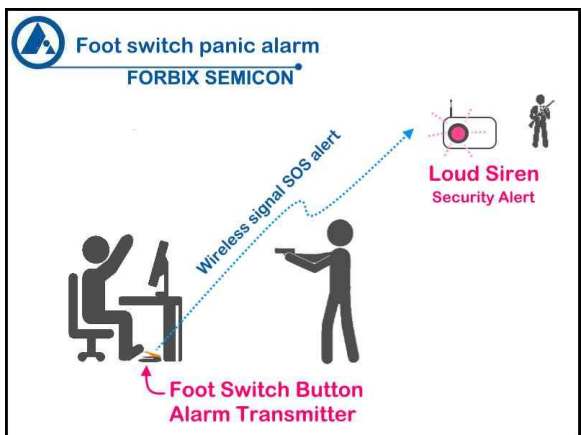
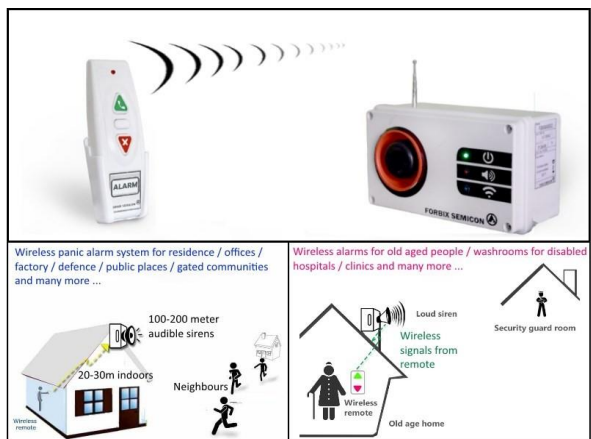
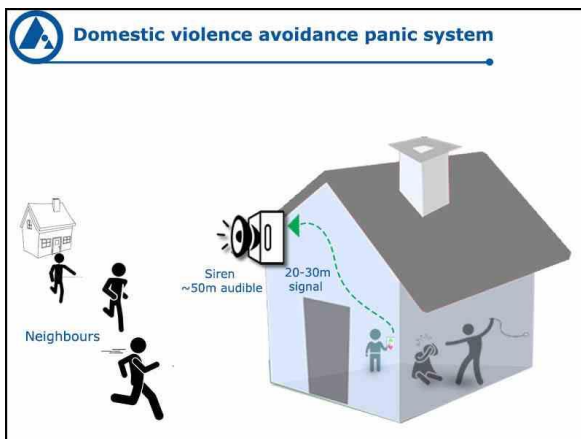
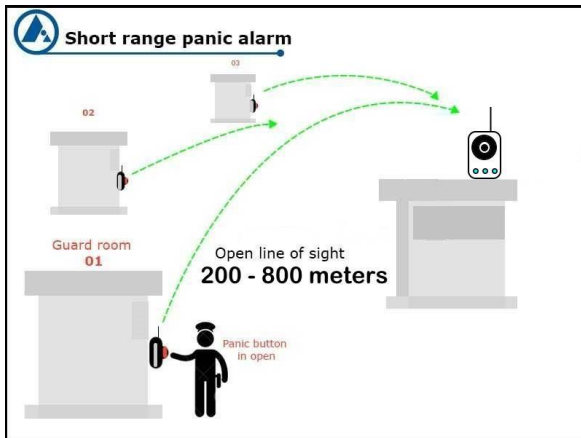

# Wireless Panic Alarm System

## Wireless Panic Alarm System – application

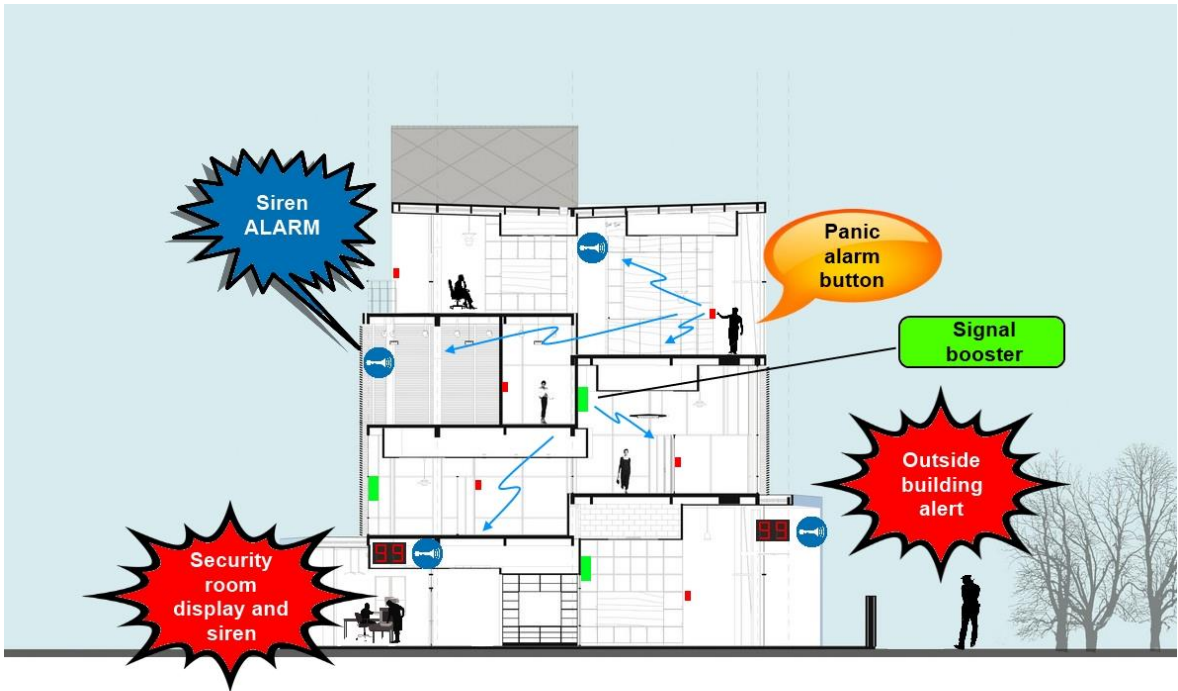

### Range of Communication

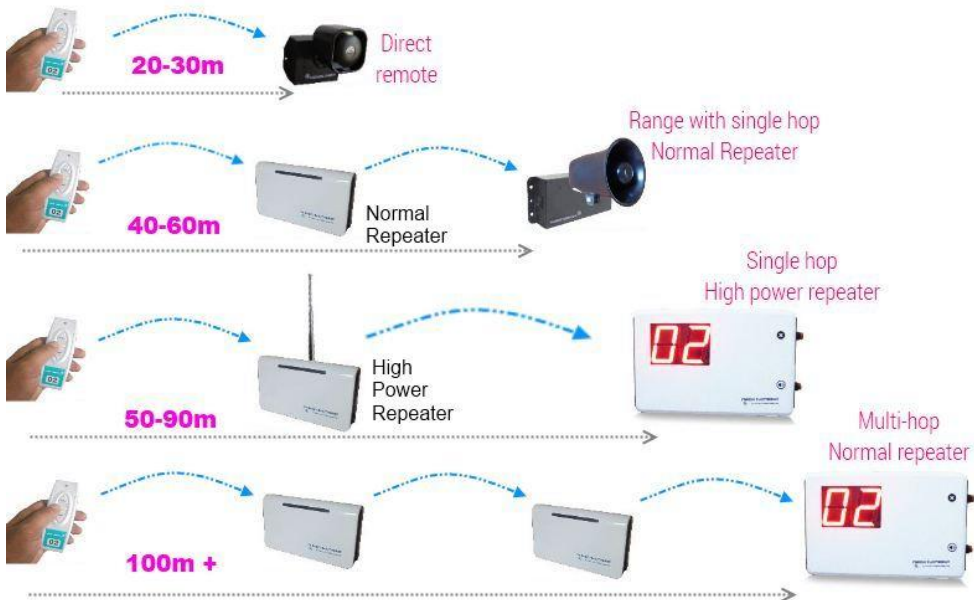

Made in India

FORBIX SEMICON 

# Wireless Attendant Calling System

## Components of Wireless Attendant Calling System

### Call Bell for Old Aged People

Signal range: 30-40m (indoors)  
Battery operated (3-4yrs battery life)  
1 to 6 calling points per receiver  
85 db beeping sound with volume control  
Works on 12VDC (adapter)

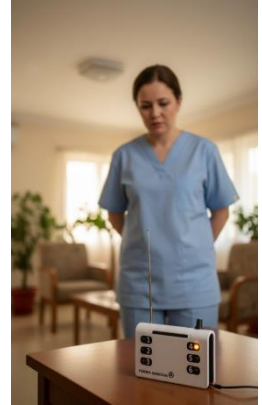

### Peon Call Bell for Office

Signal range: 30-40m (indoors)  
Battery operated (3-4yrs battery life)  
6 to 10 calling points per receiver  
85 db beeping sound with volume control  
Works on 12VDC (adapter)



### Wireless Restaurant Waiter Call Bell

Signal range: 30-40m (indoors)  
Battery operated (3-4yrs battery life)  
10 to 32 calling points per receiver  
85 db beeping sound with volume control  
Works on 12VDC (adapter)



# Wireless Attendant Calling System

## Wireless Attendant Calling System – application

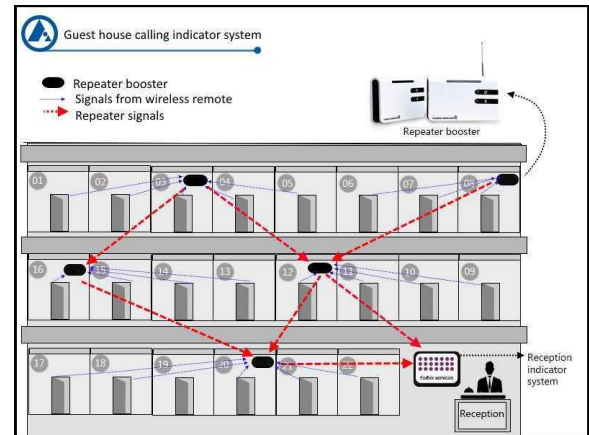
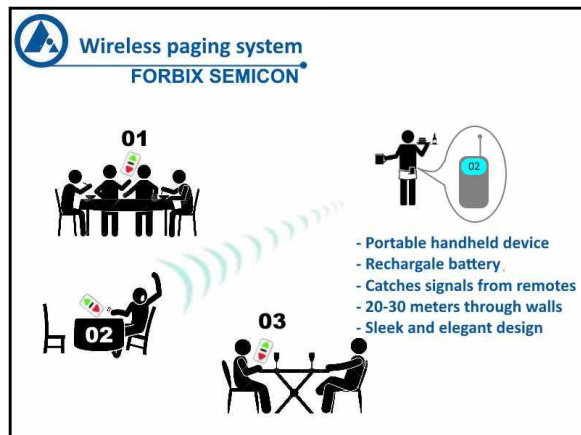
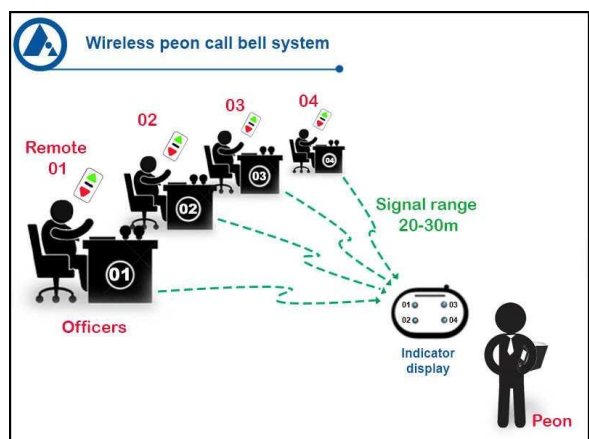
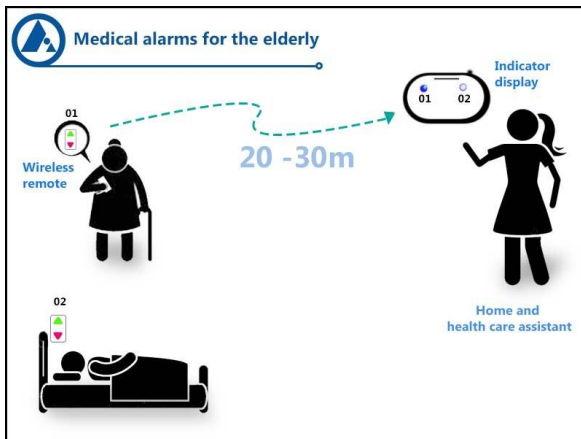
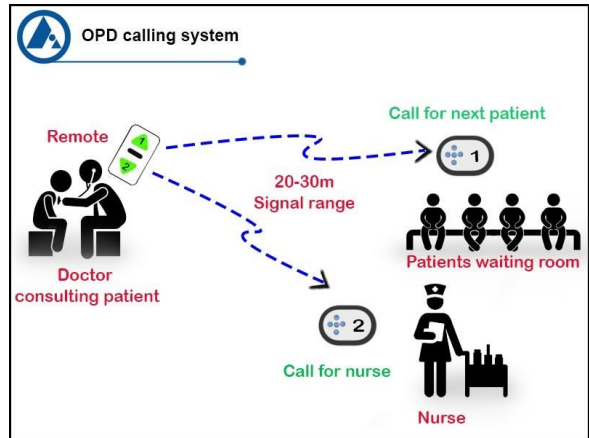
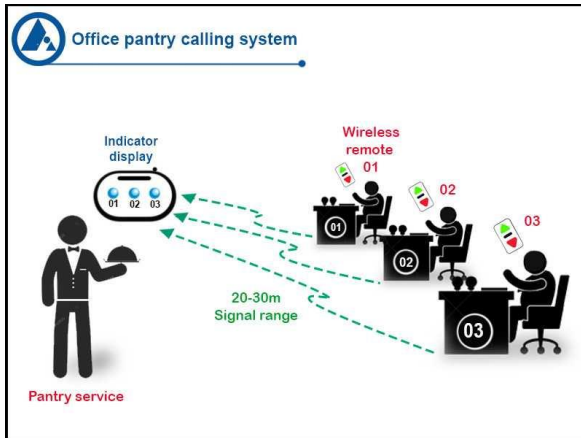

# Wireless RF Transmitter Receiver

## Components of Wireless 1..4 Channel Transmitter Receiver

### 1Channel/ 4Channel DC12V Wireless RF Transmitter Receiver

**Multi-Channel Control:** Available in 1 to 4 channel configurations to control multiple devices from one remote.

**Relay Output:** Features a clean relay contact output on the receiver, compatible with various loads (lights, motors, buzzers).

**Flexible Input Modes:** Supports both momentary (short pulse) and toggle (on/off) input signal modes for versatile applications.

**Free ISM Band:** Operates on a stable 380-480MHz frequency—no WiFi or Bluetooth pairing required.

**Signal Range between transmitter and receiver:** 100-120meters outdoor, 30-40meters indoors. Signals can pass through concrete walls, wood, glass, furniture etc.

### Applications:

Remote Machine Start/Stop, Emergency Stop  
Conveyer Belt and Machine Automation  
Secure Access Control, Garage Door & Gate Openers etc.  
Control, Irrigation Pumps, Greenhouse Ventilation  
Water Troughs, Storefront Signs, Drive-Thru Alerts,  
Fog Machines / Special Effects, Remote Generators,  
Light Towers.



# Wireless RF Transmitter Receiver

## Wireless Transmitter Receiver – application

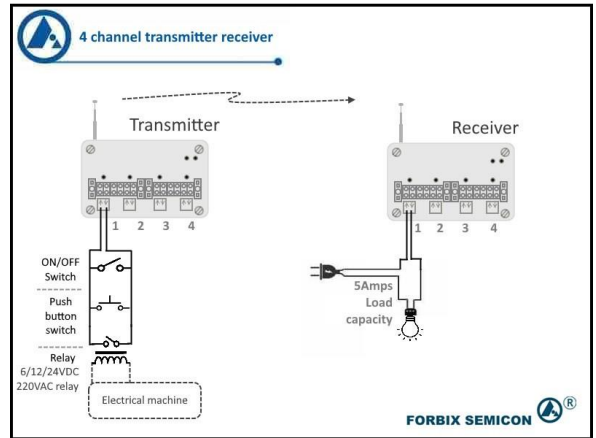
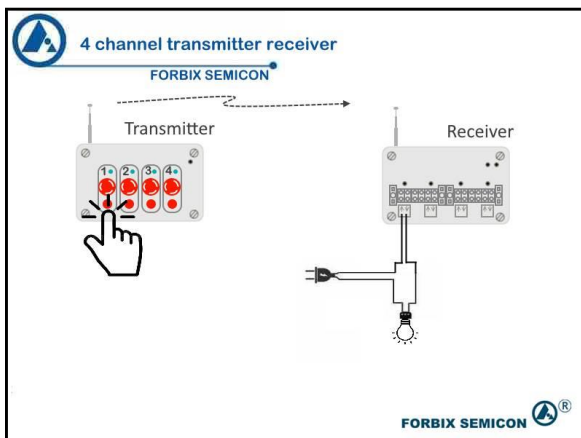
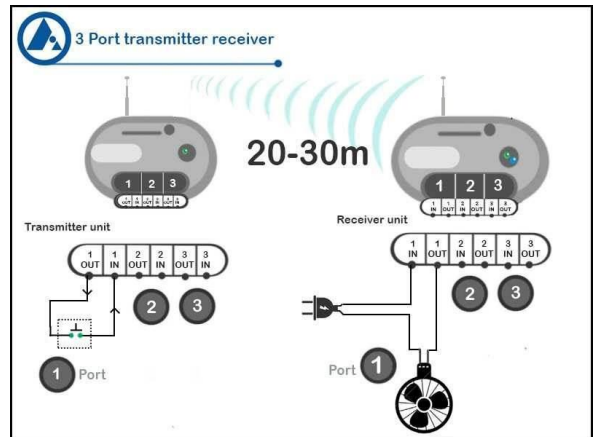
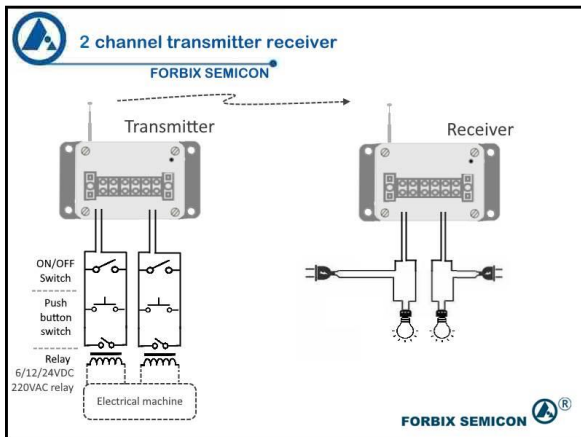
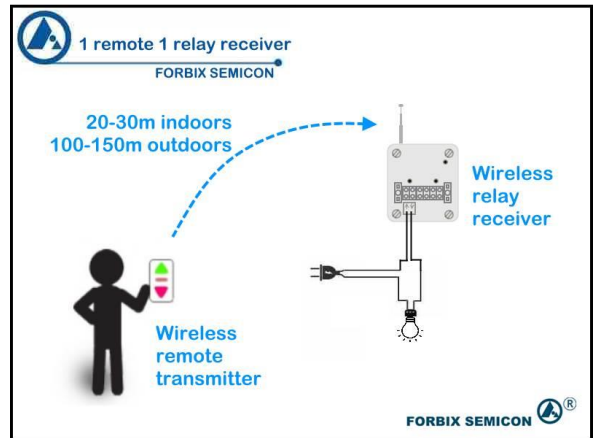
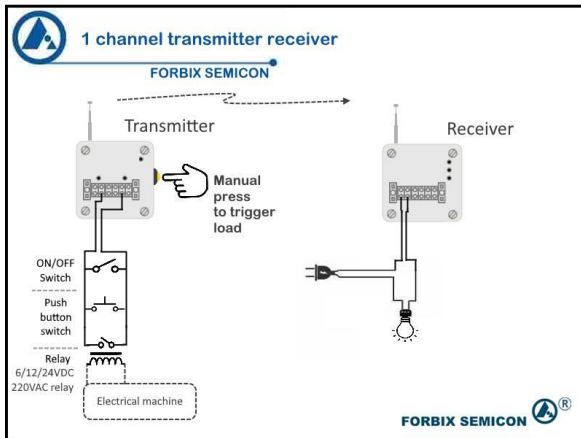

# Wireless Panic Alarm System

## Components of Wireless Panic Alarm System

**Regd. Office:**

**FORBIX SEMICON® Technologies Private Limited**

Plot No. 77, JBR Tech Park, 6th Road,  
Whitefield, Bangalore  
India, Pin – 560066

Legal details:

**CIN:**U31909KA2021PTC156093

**PAN:**AAECF8700F

**HSN:**8542 9000

**GSTIN:**29AAECF8700F1ZO

**Trade Mark No.:**4216274, Class 9

---

**Subsidiary Division:**

**FORBIX OÜ**

Harju maakond, Tallinn,  
Kesklinna linnaosa,  
Sakala tn 7-2, 10141  
Estonia

Legal details:

Registry Code: 14366377

VAT No: EE102037683

---

Website: <https://www.forbixindia.com>

Email: [sales@forbixindia.com](mailto:sales@forbixindia.com)

© 2026 FORBIX SEMICON. All Rights Reserved