

FBXPC01A : Wireless motor pump control system

Technical specification



Model: FBXPC01A

Range of communication:

20 – 30 meter indoors
100 – 120 outdoors (line of sight)

Remote controller (hand held):

Battery operated (12VDC), battery type: 23A
Battery life 2-4 years
Battery replicable: Yes
Remote controller size: 120 x 40 x 20 mm
Remote controller weight: 45 gms

Pump controller receiver (wall mount):

Operating voltage: 12VDC
(110-220VAC-50/60Hz to 12VDC adapter supplied)
Remote controller size: 240 x 140 x 80 mm
Remote controller weight: 480 gms

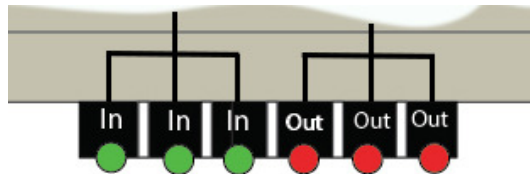

Remote buttons:

Top => to turn ON the pump
Bottom => to turn OFF the pump

Pump controller buttons:

RED button: Not pressed (default) => Remote mode
RED button pressed => Controller in manual mode

Indicators for pump controller receiver:

Power: GREEN
Sync: BLUE
Remote mode: RED
Manual mode: RED
Start contactor: YELLOW
Motor ON: GREEN

Contactor points:

1 nos. of potential free relay contactor (**30Amp**) capacity @ 220VAC. Start contactor (momentary ON) to activate the motor start. Start contactor is in parallel connection to the start button of the starter. Second contactor (in series to the stop button) for turning off the motor

Application and features:

Turning motor pump ON/OFF from a distant location
Automation / manual mode of operation
Automatic mode: Remote controller used to turn ON/OFF
Manual mode: Existing pump starter used to turn ON/OFF
(In manual mode, remote controller signals are bypassed)

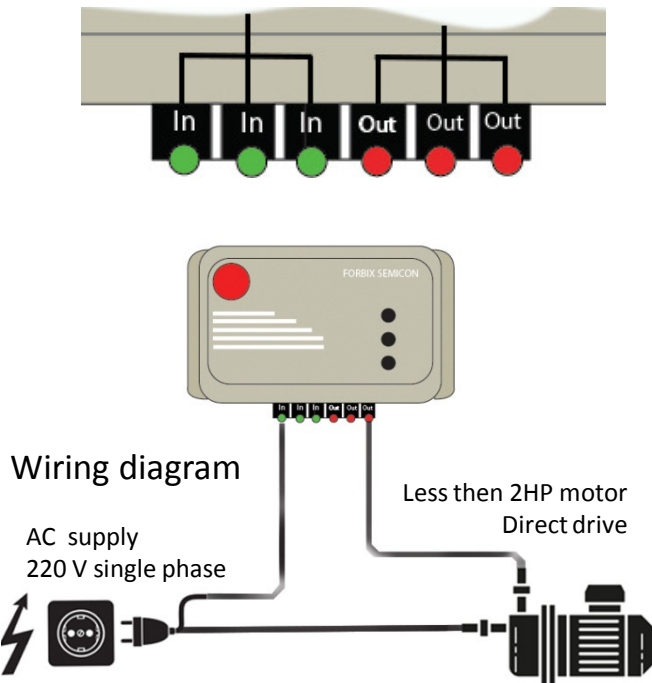

FORBIX SEMICON INDIA PVT. LTD.
Bangalore, India
Website: <https://www.forbixindia.com>
+91 9742370190 / +91 9742159846

FORBIX Osäuhing,
Tallinn, Estonia
Website: <https://www.forbix.eu>
+372 880 1510

Email: sales@forbixindia.com